

CASE II
AGRICULTURE
FOR THOSE WHO DEMAND MORE

FARMLIFT

TELESCOPIC LOADER 74 - 146 HP





TAKE YOUR BUSINESS

To new heights



Case IH has always catered for the needs of almost every type of farm, and the Farmlift line of telescopic loaders continues that tradition. Where there is grain to be loaded, bags to be shifted, bales to be stacked, manure to be moved, Case IH Farmlift telescopic loaders bring the same qualities you have come to expect from Case IH tractors and harvest equipment to the job of moving every material on the farm.

With a range of six models, with lift capacities from 2,500 to 4,200kg and a maximum lift height of 9.1m, the Farmlift line bears the same hallmarks that make every Case IH machine worthy of the name - ruggedness, reliability and comfort, coupled with power, speed and agility.

FARMLIFT. A MODEL TO LIFT EVERY LOAD.

HIGH SAFETY REQUIREMENTS

The Farmlift models feature heavy-duty frames to improve safety. The boom is designed to maximise rigidity and stability. In addition, an anti-tipping device comes standard on all models and guarantees maximal security during your operations.



DESIGNED

For handling efficiency

From the compact 526, just 1.8m wide and less than 2m high, to the work-hungry 4,200kg max capacity of the 742 and the enormous 9.1m reach of the 935, and plenty of models in between, there's a machine to meet every need in the Farmlift range. We designed and built the range to meet the varied needs of today's agriculture – from small farms to the largest operations. Whatever model you choose, you know you can count on superior operating comfort, short loading times and quick vehicle response.

FARMLIFT. DRIVES THE BUSINESS.

Models	Lift capacity	Max. reach	Engine rated / Max. power	Transmission	Load sensing hydraulic system
Farmlift 742	4.2to	7.0m	129hp / 146hp	6x3 Autoshift	Variable Piston Pump 140l
Farmlift 636	3.6to	6.1m	129hp / 146hp	6x3 Autoshift	Variable Piston Pump 140l
Farmlift 935	3,5to	9.1m	121hp / 133hp	4x3 Powershift / 6x3 Autoshift	Gear Pump 120l (optional variable piston pump 140l)
Farmlift 737	3.7to	7.0m	121hp / 133hp	4x3 Powershift / 6x3 Autoshift	Gear Pump 120l (optional variable piston pump 140l)
Farmlift 633	3.3to	6.1m	121hp / 133hp	4x3 Powershift / 6x3 Autoshift	Gear Pump 120l (optional variable piston pump 140l)
Farmlift 526	2.6to	5.7m	74hp	Hydro 1 speed	Gear Pump 80l





WORK IN COMFORT

All Farmlift models come with high visibility, low noise level and outstanding ergonomics. From the simplicity of the Farmlift 526 to the luxurious cab of the Farmlift 742, you can choose the model that best suits your needs and comfort requirements. Plus, the ventilation and heating system grant maximum efficiency.

Air conditioning is available on all models.

THE RIGHT SIZE FOR EVERY JOB

Compact size, a tight turning radius and low centre of gravity the Farmlift stands out as a leader. The smallest model of the range is only 2m high and 1.80m wide. And if you need high lift capacity, even the model at the top of the range is very compact and the three steering modes enable you to work in the most confined spaces.

ALL THE POWER YOU NEED

Every engine in the range is designed to deliver maximum efficiency. Ranging from the 74hp Farmlift 526 to the 146hp 742 at the top of the range, you always have the power you need.

HYDRAULIC EFFICIENCY

Every model has a hydraulic system to match its power and efficiency. The robust gear pumps deliver fast cycle times for maximum productivity. The Farmlift 526 features an 80 litre/minute hydraulic pump, the Farmlift 633, 737 and 935 a 120 litre/minute pump or optionally a 140l/min. CCLS pump, which comes standard on the Farmlift 636 and 742.



744

CASE IH

CASE IH

SAFETY LABELS



TAKE COMMAND

In comfort

- 1** Everything in full control in the cab of the 633, 737 and 935 Farmlift.
- 2** Loads are always visible with the expansive glass area.
- 3** Ready to hand – your controls for operation (636 & 742 models).

Case IH is known for building some of the best tractors in the industry. Today, that design and engineering know-how is available to telescopic loader buyers; with excellent driving position and ergonomics, it is easy to get comfortable in a Farmlift. Controls fall easily to hand, the ergonomic joystick makes for fast and safe operation and the all-round vision ensures safe and easy operation.

Enjoy supreme comfort in the cab of the 636 and 742 models with a luxurious seat, the optional air suspension further enhances the driving experience. The backlit joystick is integrated into the right-hand side armrest to facilitate operations. It incorporates both shuttle direction change and gear selection features. For even more comfort, a power shuttle control lever can be ordered at steering column for dual control of forward and reverse selection.

The Farmlift 633, 737 and 935 all enjoy a high standard of specifications. The ergonomic joystick, placed on the console, falls into the operator's right hand, the mechanically-suspension seat accounts for optimal comfort.

While the 526 is designed for smaller operations and areas where access is at a premium, we did not skimp on specifications. Despite its lower-profile cabin, the 526 retains the same familiar Case IH feel of larger models, with an almost unimpeded vision.

For additional comfort, air conditioning is available on all models. And to tackle long days you can specify the 360° lighting package.

FARMLIFT. YOUR BEST ASSET.

ADVANTAGES

- Premium operator cab
- High specification standards
- Low profile cab
- Optimal all-round and upwards vision
- 360° lighting package





THE POWER TO PUT

Everything in its place

- 1** Powerful engines that allow you to take on any task
- 2** Smart design ensures compact dimensions and access to key service points
- 3** Fuel efficient and reliable engines developed with FPT

Case IH Farmlifts are machines that have been engineered for the lowest possible fuel consumption for the work they are asked to do, at the highest levels of efficiency. Combined with proven, reliable components, they make for dependable worktools that you can count on for crucial, demanding tasks.

Big jobs need big power, which is why both Farmlift 636 and 742 are equipped with powerful engines that provide 129hp and up to 146hp in peak performance. Maximum torque levels of up to 591 Nm at 1,500rpm keep the machine pushing in the most arduous of conditions.

The 133hp maximum power engine in the 633, 737 and 935 models ensures there is always sufficient power to delivering fast cycle times and full job versatility. Common rail technology accounts for high engine responsiveness and guarantees efficient handling.

The Farmlift 526 features a 74hp turbocharged engine which complements the compact dimensions and tight turning circle of the machine.

FARMLIFT. THE POWER YOU NEED.

ADVANTAGES

- Powerful Stage V engines
- Hi-eSCR after-treatment system
- Engine offer matches the requirements of each Farmlift
- Impressive torque even at lower engine speeds
- 500-hour oil change intervals







1

3

THE ULTIMATE TRANSMISSION

To take on any task

- 1 Controls and ergonomic joystick (Farmlift 633,737,935)
- 2 Low centre of gravity for optimal work

The transmission on Farmlift models is developed to provide exceptional performance. Wet multi-disc clutches ensure smooth and comfortable gear changes, while a declutch button eases and secures operations. An electronic modulation system for all clutches improves gear ratios for loading applications. For easier operation, the Powershuttle commands are located on the joystick.

All Farmlifts are fitted with high dynamic load capability axles with limited slip differential (LSD) on the front axle, another can be specified for the rear axle. Inboard wet disc service brakes offer excellent stopping power whilst being well-protected and simple to service.

For comfortable and safe driving, a SAHR (spring applied hydraulic release) parking brake is standard on all models.

Farmlift 633, 737 and 935 models are equipped as standard with a 4x3 Powershift transmission, with manual shifting. The optional 6x3 semi-automatic transmission can operate automatically through gears 4-5-6 and capable of a maximum 34kph top speed.

On the 636 and 742 models, the standard 6x3 Autoshift is fully automatic through the forward speeds and can also be operated with the semi-automatic through forward gears 2-3-4. These models benefit from 40kph top speed for faster travel between jobs, and a memory shuttle feature, where the power shuttle selects the last-used forward and reverse gear when changing direction.

Then, the compact 526 features an easy to use hydrostatic transmission.

FARMLIFT. MAXIMUM TRACTION.

ADVANTAGES

- Excellent performance regardless the conditions
- Easy operations with Powershuttle commands located on the joystick
- Proven and reliable components for dependable operations
- New transmission gear ratios for quicker acceleration and increased drive torque



FARMLIFT 636 CYCLE TIME	
Lift	6.7 sec
Lower	5.2 sec
Extend	5.2 sec
Retract	3.7 sec
Dump	2.8 sec
Rollback	2.9 sec
TOTAL TIME	26.5 sec

HYDRAULICS TO HANDLE

The heaviest jobs

1 Boom suspension system available in option

Each Farmlift model is built around a dedicated hydraulic system specifically designed for its build, weight and height capabilities. This precise component matching means that jobs can be conducted with greater precision, more quickly and more smoothly. Meanwhile the system is kept under minimum stress and operates at maximum power and at low temperatures.

Farmlift 636 and 742 models feature a 140l/min variable piston pump with load sensing system, which automatically adjusts oil flow at lower engine speeds. This oil flow rate means a lift-lower-extend-retract-dump-rollback time of just 26.5sec for the Farmlift 636. All hydraulic features are electro-proportionally controlled by the integrated multifunction electronic joystick, located on the end of the seat armrest, offering ergonomic excellence.

Located on the front light support bracket, the optional auxiliary pressure release (APR) switch simplifies connecting attachments which require auxiliary hydraulic power.

The Farmlift 633 (3.3t to 6.1m), 737 (3.7t to 7m) and 935 (3.5t to 9.1m) models are now fitted with a 120l/min gear pump and can be specified 140l/min variable piston pump. This pump enhances performances and ensures smoother and quicker operations overall. The ergonomic mechanical joystick allows you to control of up to three functions at the same time.

On the Farmlift 526, lifting 2.6t to 5.7m, a robust, reliable load-sensing gear pump provides an impressive 80l/min oil flow; two operations can be processed simultaneously.

ADVANTAGES

- Dedicated hydraulic for every model
- CCLS 140l/min. pump available on 633, 737 and 935 models
- Shortened cycle times
- Work with a standard equipment loader at the same speed as a high spec machine
- Optional boom suspension or floating position
- Auxiliary pressure release (APR) switch simplifies connecting attachments

FARMLIFT. YOUR BEST ASSET.





ADVANTAGES

- Strong and stable chassis
- Fully mounted boom for extremely effective counterbalance
- Highest standard of safety and stability
- Square wheelbase concept to stay firmly planted on the ground



- 1 Whatever the job at hand, excellent crowd and dump angles ensure that every load is a full one and discharge is fast.
- 2 Be informed of your load limits by the monitor security system

THE BEST BOOM

In the business

Case IH engineers have thought through every detail to ensure that Farmlift features save you time, make your life simpler, and your farm more productive. The optional quick coupling/uncoupling system option available on all Farmlifts makes changing attachments as simple as possible. Your safety is just as important and the load status system fitted to every Farmlift ensures that maximum load capabilities cannot be exceeded.

Excellent stability and smooth boom operation are guaranteed by the combined effects of the Farmlift's hydraulic compensation ram and its tilt ram. These work together to ensure that the loader's attachment remains parallel to the ground at all times. This accounts for faster cycle times, and more loads shifted in a day.

For even more efficiency, the Farmlift 633, 737 and 935 can be specified with a new kinematic option that allows faster cycle time and quicker unloading with a 142 dumping angle.

FARMLIFT. DRIVES THE BUSINESS.



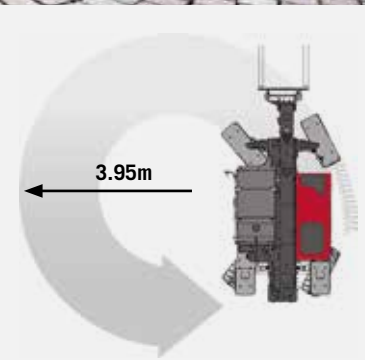

1



2



3



CASE IH FARMLIFT

Compact, stable, agile

Case IH Farmlifts are designed to give the operator complete confidence in his machine. Compact dimensions were one of the key design criteria across the whole range of machines when our designers drew up their first drafts. All Farmlifts have a low centre of gravity for optimal traction, a compact turning radius, and an exceptional agility that comes courtesy of their corner-to-corner wheelbase concept.

Selectable three-way steering features on all Farmlifts, making work easier even in the most challenging surroundings. Three different steering modes are available for working in the most confined spaces.

All models (except the 526) are featured with the automatic steering alignment which avoid checking if the front and rear wheels are aligned before changing the steering modes.

While they have a 3m wheelbase for excellent stability, Farmlift 633, 636, 737, 742 and 935 models offer a tight outside turning radius of 3.91m. That means less time spent manoeuvring and more accuracy.

The compact dimensions of the Farmlift 526, just 1.8m wide and with a working height of under 2m, makes it the perfect telescopic loader for work in low buildings and through narrow doorways where it may not be possible to work with other types of telescopic loaders.

FARMLIFT. STABILITY AND MANEUVRABILITY AT THEIR BEST.

- 1** Four wheel steer: minimises the Farmlift's turning cycle and maximises manoeuvrability.
- 2** Crab steer: angled driving in a straight line, for working along walls, for example.
- 3** Front wheel steer: ideal for transport applications and general road work.

WHEELBASE BENEFITS:

- Improved comfort thanks to the 3m-long wheelbase
- The corner-to-corner concept offers higher stability and more even weight distribution
- The low gravity point gives increased stability when working on uneven terrain
- Rear mounted boom provides a natural counterbalance when lifting the heaviest loads



NEEDFUL THINGS

Connected in seconds

- 1 Digging bucket
- 2 Re-handling bucket
- 3 Grain bucket
- 4 Grab bucket
- 5 Fork with grapple
- 6 Big or round bale grab
- 7 Bale spike 3 tine
- 8 Wrapped bale gripper

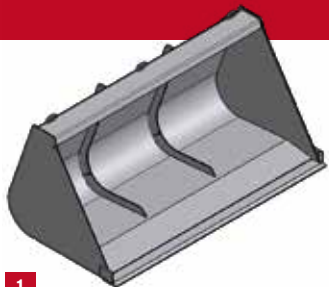

1

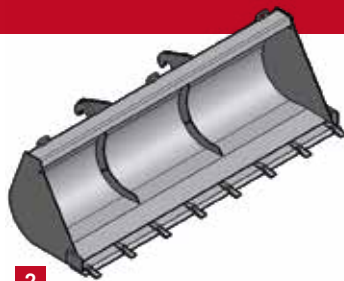

2

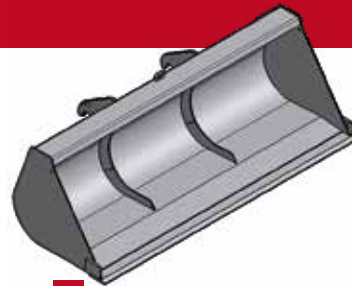

3



4



5

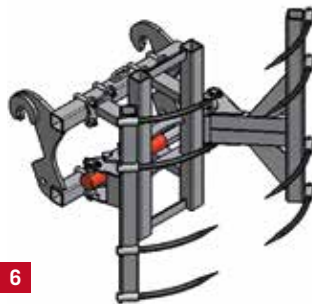

6

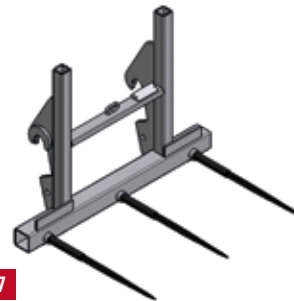

7



8



SERVICING SIMPLICITY

Daily

Servicing a Case IH Farmlift is a cinch. Daily checks can be easily completed in seconds, access to engine oil dipstick, water coolant filler, air filter and radiators is easy and convenient. The opening engine hood can be quickly raised out of the way if greater access is needed. When engine, service is required, the design of the engine bay gives you a wide and complete access to the compartment and to key components.

500-hour long service intervals between oil changes keep you working longer. Refilling the urea tank and refueling is easy from ground level and the diesel-tank cap is lockable to prevent theft.

Farmlift models feature two automatic lubrication systems:

- An electronically-controlled pump for greasing of chassis, axles, boom pivot points and cylinders
- Hydraulically-operated lubrication pump sited on the boom headstock that greases all boom movement points, controlled by the movement of the tilt ram cylinder

Both systems are designed to ensure grease points are always correctly lubricated, while allowing the operator to cut servicing time and keep clean hands.

FARMLIFT. SIMPLE, RELIABLE.

ADVANTAGES

- Easy, ground-level access to all service points
- 500 hours oil change interval
- Easy-to-raise and wide-opening engine compartment bay
- Rear mounted boom provides a natural counterbalance when lifting the heaviest loads
- 2 automatic lubrication systems allowing the operator to cut servicing time





REDUCE THE CONSUMPTION OF RESOURCES BY MOVING FROM FOSSIL FUELS TO A **RENEWABLE ENERGY SYSTEM**



INCREASE AGRICULTURAL PRODUCTIVITY TO **IMPROVE FOOD AVAILABILITY**



REDUCE **ENVIRONMENTAL IMPACT** AND OPTIMIZE **ENERGY CONSUMPTION** IN ALL COMPANY PROCESSES



INCREASE OPPORTUNITIES FOR EXCHANGING **IDEAS** AND **GOOD PRACTICES** WITH ALL **STAKEHOLDERS**

SUSTAINABILITY

It's part of everything we do

Case IH pertenece a CNH Industrial, una de las empresas de bienes de capital más grandes del mundo. Está firmemente centrada en sus responsabilidades ambientales y ha liderado nuevas veces el índice de sostenibilidad de Dow Jones.

- 91% of waste is recovered
- 27.5% of water used is recycled
- 56% of electricity used is from renewable sources.

Being a global leader in capital goods carries great responsibilities, which means that we must be accountable for every global activity we perform. Our responsibility does not stop at the factory gate, and we have made great efforts to be proactive when it comes to the broader global issues surrounding sustainability.

Over the years, our work in research and development has been geared towards ensuring that our products continue to achieve increasingly high standards in terms of safety and eco-compatibility.

Rather than limiting customers to a choice between low operating costs and eco-efficiency, our strategy is to offer products that deliver both.

By providing innovative products and solutions that abide by environmentally responsible operating practices, Case IH is doing its part to address global issues such as climate change. Today's companies face complex and interconnected challenges that demand an ever-evolving approach to sustainability, a scenario that Case IH believes is an important driver in creating long-term value for all its stakeholders, which is a core objective of the brand.

At Case IH, our engineers are focused on producing machines that not only work on the land, but work with it too.

CASE IH. ALWAYS FUTURE-FOCUSED.

THE SUSTAINABILITY GROWTH DRIVERS ARE:

- Necessity to feed an increasing population
- Importance of soil protection for future generations
- Growing sustainable farming solutions
- Increasing public awareness
- Fostering people engagement



SERVICE TEAM.

Be a farmer, we take care of the rest.

The Case IH **SERVICETEAM**, a strong dealer network backed up by local Case IH market teams, industry leading Case IH supporting tools, modern training methods, best in class spare parts support and logistics performance providing Case IH customers with an excellent all-encompassing after-sales service, keeping customers farming!

TECHNICAL SUPPORT | SERVICE | PARTS | MAXSERVICE | SERVICEFINANCE

GENUINEPARTS WE KEEP YOUR EQUIPMENT RUNNING.

Your local Case IH dealer and our dedicated 24/7 parts call centre technicians and their logistic colleagues are all part of the Case IH ServiceTeam network. They're highly trained to give you expert advice and solve problems, ensuring the correct, genuine Case IH parts are located and dispatched right away, reaching you next day or sooner to keep your machine in top condition.

MAXSERVICE AROUND THE CLOCK. AROUND THE COUNTRY.

When you're working around the clock, MaxService ensures you're never alone. It's a dedicated helpline that connects you to the Case IH ServiceTeam 24/7. Call technicians at your local dealer are ready to assist with technical advice, software solutions and genuine parts ordering. At peak season, we can keep you farming with breakdown assistance.

SAFEGUARD GARANTÍA DE TRES AÑOS.

Las mejores cosas llegan de tres en tres: Nuestros altísimos estándares de calidad y la mejora continua de nuestros productos nos han permitido ofrecer una garantía de fábrica de tres años. La garantía cubre todas las reparaciones necesarias en el segundo y el tercer año, hasta donde alcanza la garantía básica. Todas las reparaciones en garantía incluyen mano de obra y piezas originales Case IH sin costes imprevistos para el usuario. Consulta el detalle de las condiciones llamando al distribuidor Case IH de tu zona.



CAPITAL

AN OPTIMAL FINANCING SOLUTION FOR EVERY INVESTMENT.

CNH Industrial Capital is the financing company for Case IH. Our employees are financial experts and have many years of experience in agriculture. We do not only know about Case IH products and the market, we also understand the individual requirements of your operations. Therefore we are always able to offer you a financial solution for your new investments that is tailored specifically to your operational requirements. Our most important goal is improving the profitability of your investments!

MODELS	FARMLIFT 636	FARMLIFT 742	FARMLIFT 633	FARMLIFT 737	FARMLIFT 935	FARMLIFT 526
Max. lift capacity (kg)	3,600	4,200	3,300	3,700	3,500	2,600
Max. lift height (m)	6.1	7.0	6.1	7.0	9.1	5.7
CYCLING TIMES (SECONDS)						
Lift (gear pump / piston pump)	- / 6.7	- / 6.7	7.4 / 6.7	7.4 / 6.7	7.4 / 6.7	- / 7.8
Lower (gear pump / piston pump)	- / 5.2	- / 5.2	5.6 / 5.2	5.6 / 5.2	5.6 / 5.2	- / 4.1
Extend (gear pump / piston pump)	- / 5.2	- / 6.2	5.5 / 5.2	6.5 / 6.2	8.3 / 7.9	- / 6.1
Retract (gear pump / piston pump)	- / 3.7	- / 4.5	3.7 / 3.7	4.4 / 4.5	6 / 6.3	- / 3.4
Dump (gear pump / piston pump)	- / 2.8	- / 2.8	3.1 / 2.8	3.1 / 2.8	3.1 / 2.8	- / 3.5
Rollback (gear pump / piston pump)	- / 2.8	- / 2.9	3.2 / 2.8	3.4 / 2.9	3.4 / 2.9	- / 2.2
Total Time (gear pump / piston pump)	26.4	28.3	28.5 / 26.4	30.4 / 28.3	33.8 / 31.8	- / 27.1
BUCKET ANGLE						
Dump angle		118°		109° (optional 118°)		118°
Total Rotation angle		142°		131° (optional 142°)		129°
ENGINE						
Type	4 cyl., EURO Stage V, Common Rail, Turbo intercooler					4 cyl. EURO Stage V
Displacement (cm³)	4,485					3,331
Rated power ISO14396 - ECE R120 @ U/min (kW/hp)	96 / 129 @ 2,200		89 / 121 @ 2,200		89 / 121 @ 2,200	55 / 74 @ 2,200
Max power ISO14396 - ECE R120 @ U/min (kW/hp)	107 / 146 @ 1800		98 / 133 @ 1,800			54.6 / 74 @ 2600
Max. torque ISO14396 - ECE R120 @ U/min (Nm)	591 @ 1,500		549 @ 1,500			265 @ 1,500
Tank capacity, Fuel/Urea (l)	140/27					80 / -
TRANSMISSION						
Type	6x3 Auto-Shift		Standard: 4x3 PowerShift / Optional: 6x3 Auto-shift			Hydrostatic
Powershuttle	•	•	•	•	•	•
Shifting mode	6x3 transmission (standard): Full-automatic (gears 1-6) / Semi-automatic (gears 2-4) / Manual		4x3 transmission (standard): Manual 6x3 transmission (optional): Semi-automatic (gears 4-6) / Manual			
Max. Travel speed (km/h)	40 km/h		34 km/h			30 km/h
AXLES						
Limited Slip differential Front Axle	•	•	•	•	•	•
Limited Slip differential Rear Axle	•	•	•	•	•	•
SERVICE BRAKES						
Type	oil immersed discs, hydraulic power assisted					
Discs per axle	6 front / 4 rear					6 front
Parking brake	Front axle SAHR (Spring Actuated Hydraulic Release)					
HYDRAULIC						
Gear pump 80lpm / 230 bar	-	-	-	-	-	•
Gear pump 120lpm / 240 bar	-	-	•	•	•	-
Variable piston pump 140lpm / 250bar	•	•	•	•	•	-
Tank capacity, Hydraulic oil (l)	105					80
STEERING						
Steering mode	2WS / 4WS / Crab					
WHEELS AND TYRES						
Standard	460 / 70 R24					12 x 16.5
Optional	500 / 70 R24					12 x 18
DIMENSIONS ¹⁾						
A: Length fork heel to counter weight (mm)	5,005	5,239	5,005	5,239	5,472	4,125
B: Wheel track (mm)	3,000	3,000	3,000	3,000	3,000	2,350
C: Ground clearance (mm)	415z	415	415	415	415	270
D: Max. width (mm)	2,340	2,340	2,340	2,340	2,340	1,850
E: Wheel base (mm)	1,873	1,873	1,873	1,873	1,873	1,500
F: Cab height (mm)	2,447	2,447	2,447	2,447	2,447	1,980
Total weight with forks and driver (kg)	7,935	8,000	7,935	8,000	8,580	5,350

* To comply with legislation and specification in your country ¹⁾ with standard tyres ²⁾ ECE R120 correspond to ISO 14396 and 97/68/EC or 2000/25/EC
• Standard ○ Optional – not available

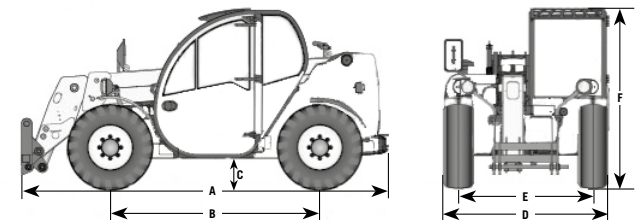

CNH Industrial Österreich GmbH
Steyrer Straße 32, A-4300 St. Valentin – Austria

Free phone: 00 800 22 73 44 00

 Safety never hurts! Always read the Operator's Manual before working with any equipment. Inspect equipment before using it, and be sure it is operating properly. Follow the product safety signs, and use any safety features provided. This literature has been published for worldwide circulation. The standard and optional equipment and the availability of individual models may vary from one country to the next. Case IH reserves the right to undertake modifications without prior notice to the design and technical equipment at all times without this resulting in any obligation whatsoever to make such modifications to units already sold. Whilst every effort is made to ensure that the specifications, descriptions and illustrations in this brochure are correct at the time of going to press, these are also subject to change without prior notice. Illustrations may show optional equipment or may not show all standard equipment. Case IH recommends **AKCELA** lubricants.



CASE IH
AGRICULTURE
FOR THOSE WHO DEMAND MORE